

Locking Suites

The demands placed on a locking suite are varied and complex:

Primarily it is an organisational tool to enable the clear separation of responsibilities and locking authorisations controlled through the selective distribution of keys. Secondly, it provides great convenience both in private and contract application: key owners can operate many different doors with cylinder locks with a single or a few keys.

Single key system

Several different single keys (e.g. of flat entrance doors) control one or more central locking cylinders (e.g. of house entrance doors).

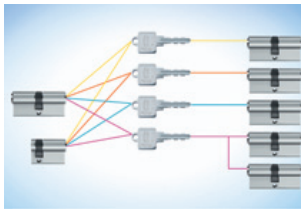

Master key system

A master key system consists of a multitude of locking cylinders each operated by an individual key. Each single locking cylinder is also controlled by the master key. The owner of a master key can operate all cylinders of a master keyed locking suite.

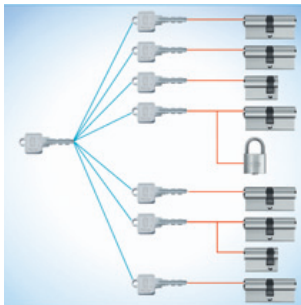

Grand master key system

Grand master key systems are systems with several authorisation levels. All locking cylinders of a grand master key system can be operated with the grand master key. A master key can control specified cylinders within the suite.

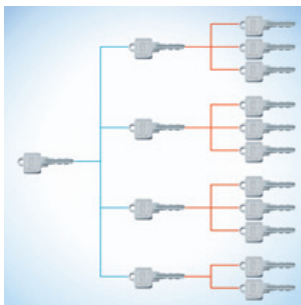

Things to keep in mind when buying a profile cylinder

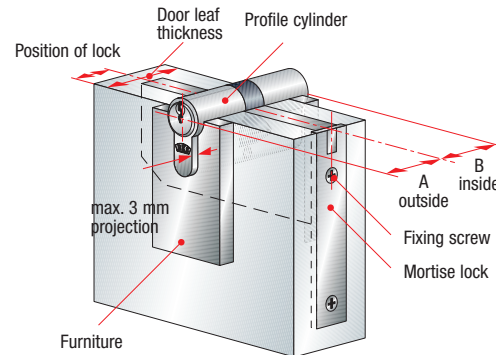

The length of the profile cylinder depends on:

door leaf thickness, position of the lock in the door leaf protrusion of furniture on the outside, protrusion of furniture on the inside

The cylinder lengths A and B are determined with regard to the thickness of door leaf and furniture. Therefore, it is important that the profile cylinder does not protrude more than 3 mm from the surface of the door furniture – especially on the outside of the door exposed to attack.

The dimensions A and B are measured from the centre of the fixing screw on the forend.

Your specialist retailer

For further products of the Gretscht-Unitas Group of Companies visit our website www.g-u.com

Gretscht-Unitas GmbH
Baubeschläge
Johann-Maus-Str. 3
D-71254 Ditzingen
Phone + 49 7156 301-0
Fax + 49 7156 301-293

BKS GmbH
Heidestr. 71
D-42549 Velbert
Phone + 49 2051 201-0
Fax + 49 2051 201-431



Series 50 MORE SECURITY WITH BKS



BKS security – sophisticated down to the smallest detail



Each cylinder with registered differ is packed and sealed in the BKS factory. The BKS security card is an indispensable cylinder accessory on which all cylinder and key specific data are memorised.

It has to be produced to the authorised BKS dealer for the subsequent ordering of keys and cylinders.

BKS security – sophisticated down to the smallest detail

Keys are “constant companions” expected to always function perfectly. Very often, they are used to operate several doors (apartment, house entrance, business room). Customers appreciate the convenient use of the reversible Series 50 key distinguishing itself by rounded bittings and the easiness with which it is inserted in the lock.

1 High-quality reversible key with newly formed key blade: with the bittings protected on one flank, the key is secured against being copied.

2 Sophisticated key design combining functionality with security

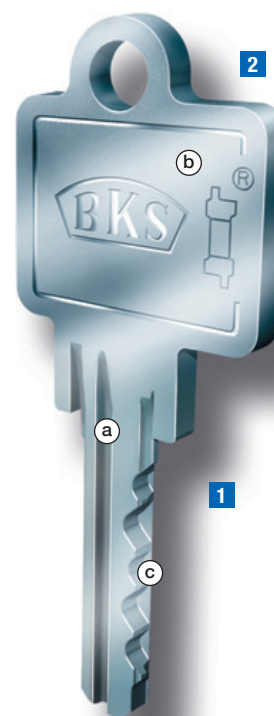

- a Key blade
- b Key bow
- c Key bittings

Features and facts speak for themselves.

The reversible key system Series 50 with 6 pins is a conventional locking system based on the proven technique of single-row pin arrangement.

Increased resistance against forced opening is provided by the drill protection or drill/pick protection feature, both available as an option.

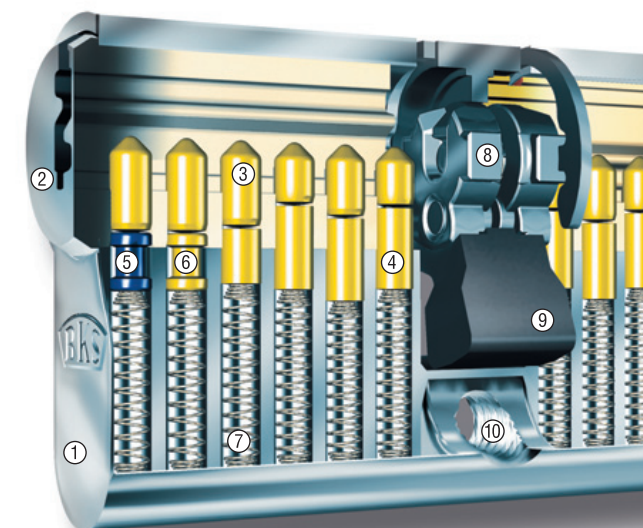

- ① Body
- ② Plug
- ③ Bronze tumbler pins
- ④ Brass cylindrical drive pin
- ⑤ Hardened steel mushroom drive pin
- ⑥ Brass mushroom drive pin
- ⑦ Drive springs
- ⑧ Coupling
- ⑨ Cam
- ⑩ Thread hole for fixing screw drive pin